

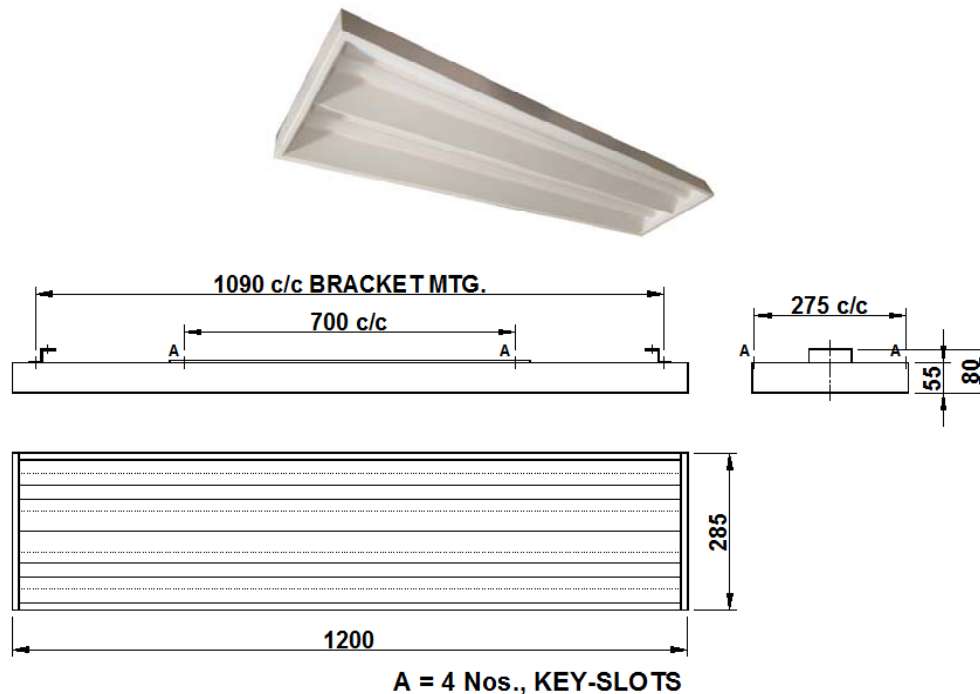

Integral LED Bay Luminaire

BTS 80W WH LED



Dimensions in mm Tolerance: +/-5

Application

- Departmental Stores and control rooms, Entrance Lobbies,
- Bank and Offices, Conference halls and control rooms,
- Hospital and laboratories, Computer centers, Etc.

Specification

- Energy saving decorative surface/suspended mounted LED luminaire.
- The elegant design enhances the aesthetic and suits indoor usage.
- CRCA steel sheet housing comprising of polycarbonate diffusers and White (WH) LED's.
- Luminaire is available with color temperature: White (WH) : 5700K ±300K
- White powder coated reflector for enhanced light distribution.
- Control gear access on top side.
- Wired with constant current driver.
- Degree of protection: IP20

Note : "Y" type suspension for suspended mounting to be order separately :
Cat. Ref. **BTS SUSPENSION 1.5M - 953518**

Electrical Data

Product Code	Cat. Ref.	System Wattage (W)	Nominal Voltage (V)	Mains Current in Milli Amps. At 240 V	Power Factor	Lumen Package
169742	BTS 80W WH LED	80W	240	350	0.95	8428 lm

Data subject to variation due to change/improvement in the design, materials and processes.

<p>BAJAJ LUMINAIRE Making the difference</p>	DRAWN	KPM	30-10-2014	FOR –
	CHECKED	SP		REV - 1 DATE--08-02-2016
	APPROVED	DVRS		DRG.No
	DATA SHEET RELEASED ON DT-			
BAJAJ ELECTRICALS LIMITED 15/17, SANT SAVTA MARG, REAY ROAD, MUMBAI-400 010.				* E-mail : luminaires@bajajelectricals.com