

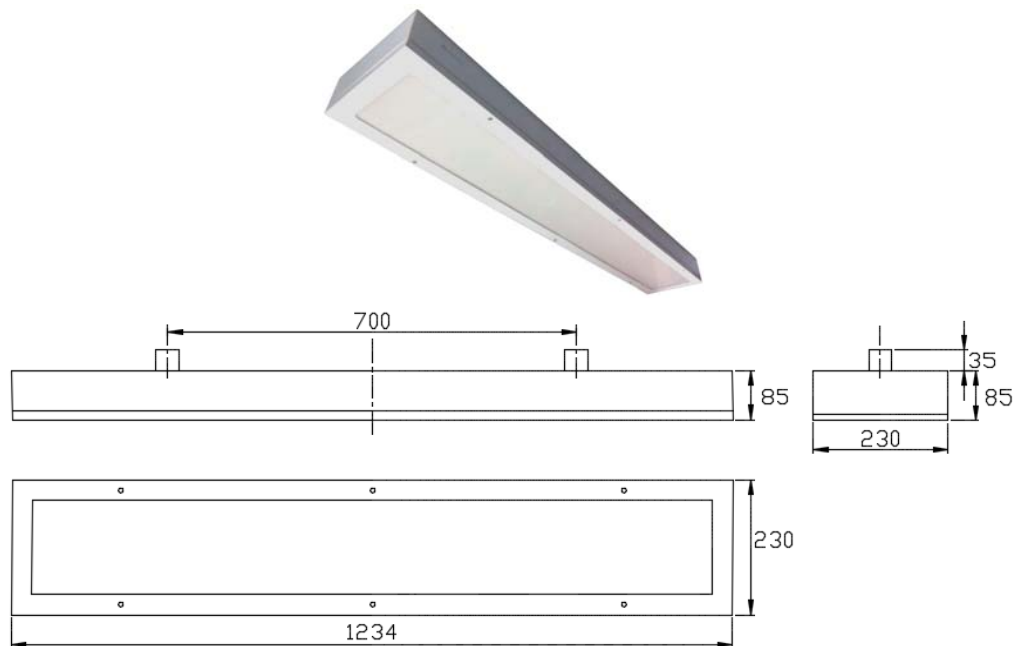

**INDUSTRIAL LIGHTING**  
**LED HighBay Luminaire**  
**BTHBX 100W LED WH**



Dimensions in mm Tolerance = +/-5

### Application

- Departmental Stores and control rooms
- Manufacturing Industries,
- Textile manufacturing
- Automobile & ancillary manufacturing,
- Warehouses,
- Railway concourse halls, Railway Platforms, etc.

### Specification / Features

- Energy saving pendent multifunctional luminaire.
- The elegant design enhances the aesthetic and suits indoor usage.
- Housing: - CRCA frame with opal diffused acrylic for smooth & uniform distribution of light.
- Frame: - Hingeable CRCA frame for easy maintenance.
- Mounting bracket: Provided with two nos. of bracket having  $\text{Ø}20$  mm holes for conduit mounting. Also suitable with wire suspension system.
- Maintenance from front side.
- Driver: - Constant current output driver, operating range 150 – 265V AC supply voltages.
- LED: -  $5700 \pm 300\text{k}$ .
- Degree of protection: IP54 (from front side).

### Electrical Data

Product Code	Cat. Ref.	System Wattage (W)	Nominal Voltage (V)	Mains Current in Amps. at 240 V AC	Power Factor
169784	BTHBX 100W LED WH	100 W	240	0.440	$\geq 0.95$

Data subject to variation due to change/improvement in the design, materials and processes.

<p><b>BAJAJ LUMINAIRE</b>  <i>Making the difference</i></p>	DRAWN	SP	01-07-2015	FOR –
	CHECKED	SP		REV - 1      DATE-20-08-15
	APPROVED	DVRS		DRG.No
	DATA SHEET RELEASED ON DT-			<b>BTHBX 100W LED WH-001</b>
<b>BAJAJ ELECTRICALS LIMITED</b> 15/17, SANT SAVTA MARG, REAY ROAD, MUMBAI-400 010.      * E-mail : <a href="mailto:luminaires@bajajelectricals.com">luminaires@bajajelectricals.com</a>				