



GLATT
LED Floodlight



NEXO
LED Streetlight

CITY'S ULTIMATE OUTDOOR LIGHTING COMPANION



CITY'S ULTIMATE OUTDOOR LIGHTING COMPANION

Amidst rapid infrastructural growth, outdoor spaces demand versatile lighting solutions. Explore the Bajaj Nexo Street Light & Glatt Flood Light, designed for cityscapes, service roads, parks, commercial, and industrial areas. Elevate your outdoor ambiance with a striking balance between aesthetics and superior performance.



GLATT
LED Floodlight



NEXO
LED Streetlight



Features



Superior and appealing aesthetics



Best in Class System Efficacy
with upto 120 lumens per watt



Superior Optical Performance
with Non-yellowing polycarbonate secondary optics



High Performance Driver
with built-in surge, over voltage, open/short circuit protection for longer service life





City
Roads



Service
Roads



Commercial
Spaces



Townships



Factory
Campus



Parks

NEXO

LED Streetlight

25W/30W/35W/45W/60W/
70W/90W/100W/120W

The Bajaj Nexo range caters to a wide range of low and mid-wattage applications providing flexibility & versatility in its usage, from illuminating campuses to lighting up city streets.

Technical Specifications

Luminaire Efficacy	120 lm/W
CCT	5700K
CRI	>70
Maintenance of Lumen Output	50,000 Hrs
Input Voltage	140-270V AC
Input Frequency	50 Hz
Power Factor	≥0.9
THD	<10%
Built-in Surge Protection	4kV (+10kV for 60W & above)
Ingress Protection	IP 66
Impact Protection	IK 08



Product Specifications & Dimensions

WATTAGE	CATEGORY REFERENCE	A	B	C	D
25W	NEXO 30L WH PO PC SD	117	260	48	42
30W	NEXO 36L WH PO PC SD	117	260	48	42
35W	NEXO 42L WH PO PC SD	135.5	298	51	42
45W	NEXO 54L WH PO PC SD	170.5	345.5	51	42
60W	NEXO 72L WH PO PC SD	170.5	345.5	51	42
70W	NEXO 84L WH PO PC SD	200	386	61	47
90W	NEXO 108L WH PO PC SD	200	386	61	47
100W	NEXO 120L WH PO PC SD	200	386	61	47
120W	NEXO 144L WH PO PC SD	200	386	61	47
150W	NEXO 180L WH PO PC SD	200	386	63	63

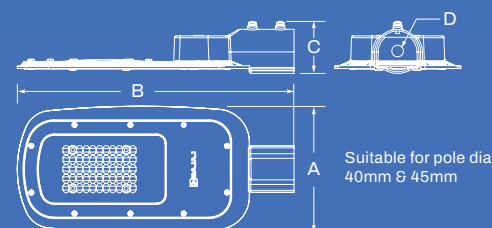



Construction sites



Billboards



Factory Campus



Local Playgrounds



Commercial Spaces



Parks

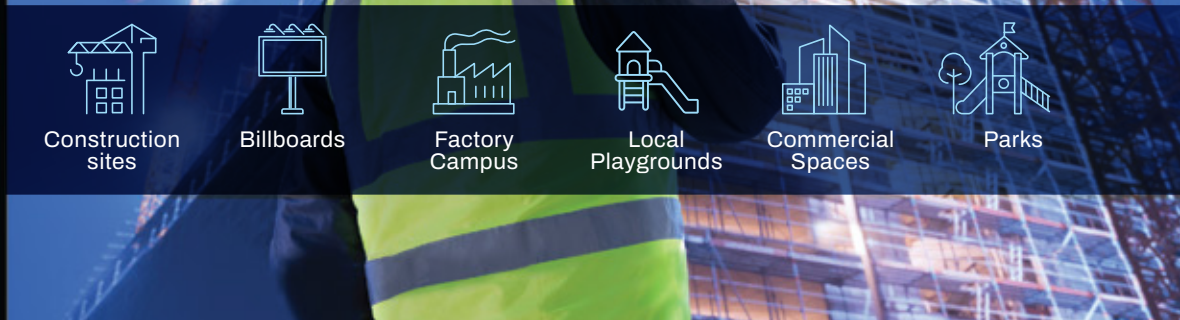

GLATT

LED Floodlight

**30W/50W/80W/
100W/120W/150W**

Presenting, Glatt LED Floodlight, a high-performance luminaire with unique prismatic design and superior aesthetic appeal that enhances every need of illumination for various applications. It is an extremely durable and energy efficient floodlight that is compact and light weight, making it a perfect choice.

Technical Specifications

Luminaire Efficacy	120 lm/W
CCT	5700K
CRI	>70
Maintenance of Lumen Output	50,000 Hrs
Beam Angle ($\pm 10\%$)	60
Input Voltage	120-280V AC
Input Frequency	50 Hz
Power Factor	≥ 0.9
THD	<10%
Built-in Surge Protection	4kV (+10kV for 100W & above)
Ingress Protection	IP 66
Impact Protection	IK 07



Product Specifications & Dimensions

WATTAGE	CATEGORY REFERENCE	A	B	C	D
30W	GLATT MT 36L WH PO PC SD	180	175	155	37
50W	GLATT MT 60L WH PO PC SD	200	208	193	37
80W	GLATT MT 96L WH PO PC SD	265	260	250	37
100W	GLATT MT 120L WH PO PC SD	265	260	250	37
120W	GLATT MT 144L WH PO PC SD	312	305	295	37
150W	GLATT MT 180L WH PO PC SD	312	305	295	37
200W	GLATT MT 240L WH PO PC SD	338	346	326	36

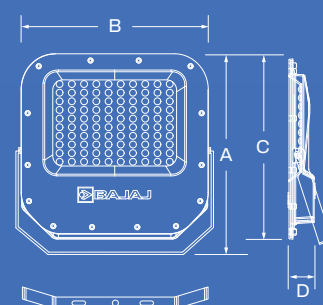



Electricals

801, Rustomjee Aspiree, Bhanu Shankar Yagnik Marg,
Off Eastern Express Highway, Sion (E),
Mumbai - 400 022 | Tel.: 022-2406 4400
Email: illumination@bajajelectricals.com | www.bajajelectricals.com

[f /BajajElecBiz](#) [X /BajajElecBiz](#) [@ /bajajelecBiz](#) [in /BajajElectricals](#)

Images of the products shown are for representation purpose only and the actual colour/size may vary.